

ROTATING RIGHT

SEEPEX PRODUCT OVERVIEW

Product groups and ranges.

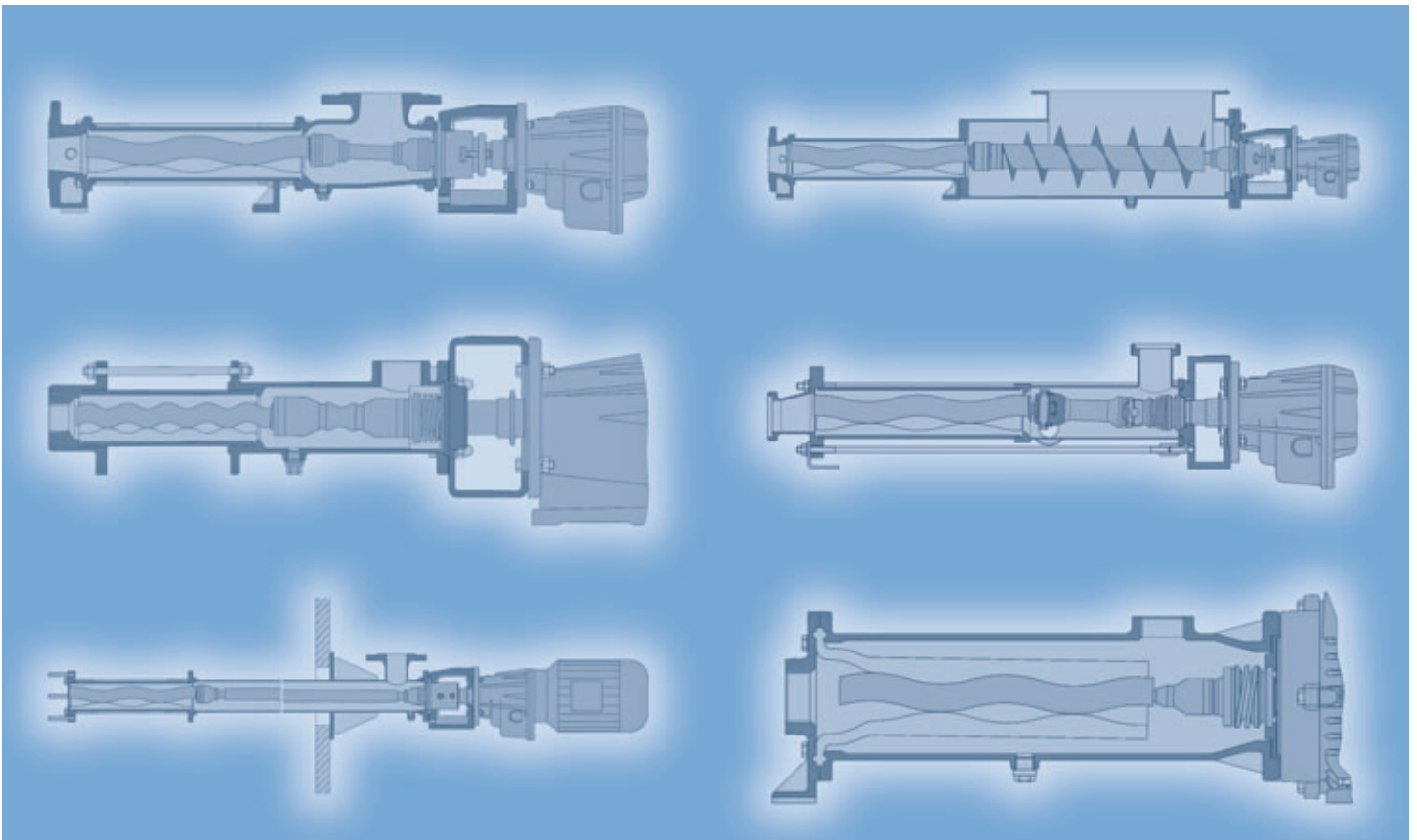

Welcome to seepex.

seepex is a leading global supplier of products and services for conveying and controlling liquids.

The first seepex progressive cavity pump was manufactured in 1972 in Bottrop, Germany. Today nearly 330 of our 520 worldwide employees work here on the development, manufacture and distribution of progressive cavity pumps, macerators and control systems to suit our customers current and future needs.



In addition to highly modern production facilities, other areas of technological excellence in Bottrop are departments and laboratories for basic research, product development/ planning as well as information technology.

For over 30 years we have been helping environmental engineers, companies dealing in foods and beverages, the chemical and paper industries, oil and gas production and industries ranging from agriculture to the zoological parks by providing them with the optimal technical and economical solutions for their conveying problems.

We have created this foundation through competent application expertise in form of consultation, development, project management and delivery. Our product and industry specialists develop tailor-made solutions for the most diverse applications. Using our modular pump system we can design a pump specifically for each application. This ensures lower energy consumption, reduced maintenance costs, increased operational safety, better utilisation of capacity and higher productivity and profits for our clients.

seepex offers you these products and services – through a worldwide sales and service network.

The pump modular system.

seepex makes progressive cavity pumps with a characteristic feature: the conveying elements are formed by the intersecting geometries of a helical rotor and a double internal helical stator. They are manufactured using a modern quality management system that satisfies the highest technical specifications, and are manufactured exclusively with the most modern technologies. Each pump is designed according to the unique requirements of the industry sector, application and product being pumped.

This has been the basis for the development of our modular pump system. There are 8 product groups in all and 27 ranges with capacities from 0.1 l/h to 500 m³/h (1cc/min. to 2200 GPM) and differential pressures of up to 48 bar (720 psi). Whether you need to transport extremely viscous media, precisely meter the smallest quantities, maintain the highest levels of hygiene, or resist the erosion caused by abrasive solids – there is a seepex solution for the most extreme applications.

When investing in a pumping system, the purchase costs only constitute a small proportion of the total investment. Consideration must be given to the life cycle costs of the entire system. Installation and commissioning costs, energy consumption, maintenance and repair costs, the expense of idle equipment and production downtimes must be kept as low as possible in the interests of efficiency and productivity.

You can achieve this through the high technical standards inherent in our pumps. The application specific construction and our extensive service program enhance each phase of the life of the pump.

seepex progressive cavity pumps in general:

Wide application range

They are particularly suitable for handling abrasive and even aggressive products with all degrees of viscosity. They can be used on fluids at temperatures of between -20°C and +180°C (0°F–360°F) and can transport products with a capacity of 0.1 l/h up to 500 m³/h (1 cc/min. to 2200 GPM), independent of discharge pressure or the DS content of the product. Differential pressures of up to 48 bar (720 psi), and higher in special cases, are available.

Gentle, precise and trouble-free

Handling sensitive products often requires a pump with specific characteristics incorporating low shear rates, accurate metering/flow together with minimum pulsation. seepex progressive cavity pumps incorporate all these qualities. Additionally they have no check valves to clog and the cavities within the pump progress from the suction to the discharge without changing their shape.

High suction lift capabilities

Typical for seepex: Excellent self priming characteristics, even on gaseous liquids are possible to 9 m, 27 ft. with reliable operation.

Versatile

Integration of a seepex progressive cavity pump into a customer's facility is easily accomplished, as they can be installed horizontally, vertically or in almost any position. Pump flow is reversible with shaft rotation. Versatility can be further extended by fitting various options of open hoppers and feeding arrangements to assist non flowable products into the pumping elements, the rotor/stator.

Service-friendly

seepex progressive cavity pumps are designed to be very service-friendly. The drive shaft plug-in connection, the universal joints, the sealing arrangements and the external flange with thru-bolt construction all contribute to the service-friendly character of our designs. It is a guiding principle of all seepex designs.

Economical

seepex guarantees state of the art products, the highest quality of all components, optimised design and manufacturing capabilities to increase efficiencies resulting in a long pump life time and low operating costs.

N – Standard pumps

The two ranges of pumps within the product group N form the basis of all seepex progressive cavity pumps. They are available with various rotor/stator geometries (conventional, 6L, even wall and Tricam) and can be applied in virtually all industrial sectors – for conveying thin to viscous media with or without solids.

Features

- Minimal pulsation, controlled flow, so that no pulsation dampers or compensators are required
 - Self-priming, even with air or gas liquid mixtures of up to 9 m (29.5') of water
 - Installation versatility as pumps can be mounted either horizontally or vertically and the suction casing can be rotated
 - Products with solids can be conveyed gently without damage
 - Direction of rotation and fluid flow are reversible
- > Conveying capacity: up to 500 m³/h (2200 GPM),
Pressure: up to 48 bar (720 psi)

Range BN

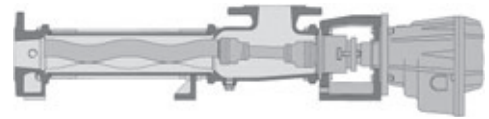

Range NS/N

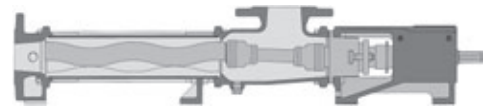

T – Open hopper pumps

There are 9 ranges of open hopper pumps. They are used for viscous media that have only little or no flowability. T pumps have a feed hopper and an auger feed screw to positively feed the product into the pumping elements.

Features

- These pumps incorporate an open hopper and auger feed screw which enables highly viscous products to be fed into the pumping elements
 - The pitch and diameter of the auger can be adjusted according to operating conditions for optimal product feed
 - The feed hopper can be designed to suit diverse application conditions
 - Pump hoppers can be fitted with integral bridge breakers
 - Range BTM pumps incorporate patented cutting knives for chopping and crushing the pumped product
- > Conveying capacity: up to 500 m³/h (2200 GPM),
Pressure: up to 48 bar (720 psi)

Range BTQ

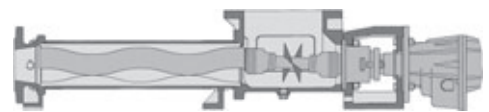

Range BT

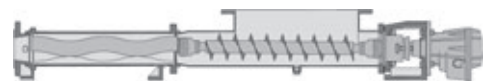

Range BTM

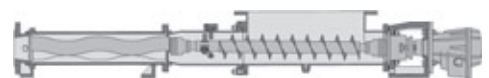

T – Open hopper pumps

Range BTE _____

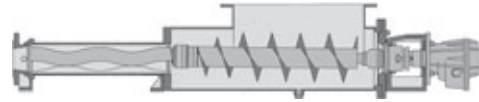

Range BTI _____

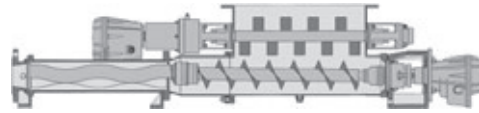

Range BTHE/BTH _____



Range BTES _____



Range BTEI _____

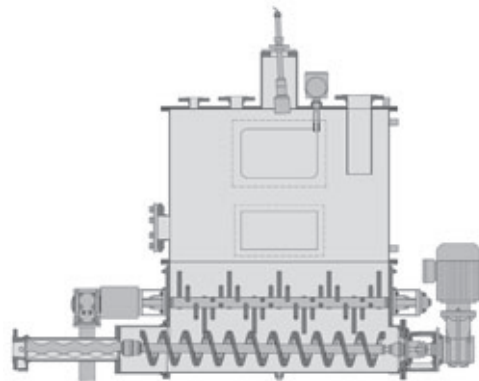

CS – Food grade pumps

The 3 product ranges of the CS product group are used primarily in the food, pharmaceutical, cosmetics and chemical industries. "C" stands for CIP (Cleaning in Place) and "S" for SIP-capability (Sterilisation In Place) of the pumps. CS pumps satisfy the highest requirements with regard to gentle conveying, sanitation, cleaning and sterilisation. They are certified acc. to the 3-A Sanitary Standard of the US and designed in compliance with the EHEDG directives

Features

- Gentle handling of flowable and high viscosity products with controllable flows and pressures
 - Easy cleaning: optimised pump casing designs with minimal residual volume that provide simple CIP operations
 - Service-friendly with easily disassembled universal joints
 - Sanitary mechanical seals selected for the respective application
 - Stator materials and secondary seals with FDA approval available
 - SIP with steam is an available option with cycled operation of the pump
- > Conveying capacity: up to 130 m³/h (575 GPM),
Pressure: up to 24 bar (360 psi)

Range BCSO

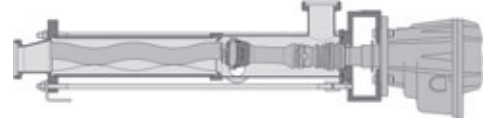

Range BCSB

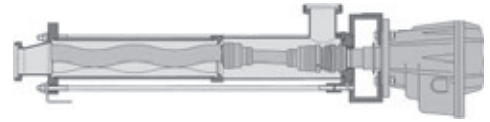

Range BTCS

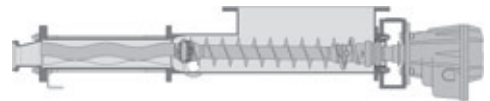

D – Dosing pumps

The 6 ranges of dosing pumps can be used in virtually all industries for the metering and dosing of precise quantities. They are particularly good for low-pulsation conveying of low to high viscosity fluids, as well as media containing solids and those that are chemically aggressive.

Features

- Simple interchangeability due to their modular construction
 - Low pulsation, no pulsation dampeners required
 - High metering accuracy (deviation $\pm 1\%$)
 - Constant flow, independent of pressure
 - Eliminates control valves
 - No ball valves to clog
- > Conveying capacity: up to 1000 l/h (380 gph),
Pressure: up to 24 bar (360 psi)

Range MD

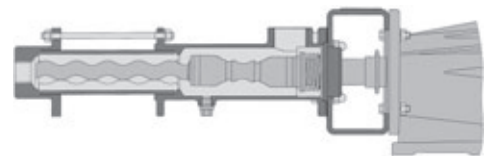

Range MDP

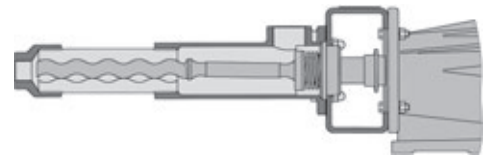

Range MDC

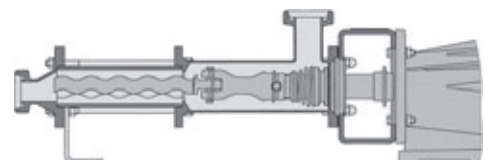

D – Dosing pumps

Range MDTC _____

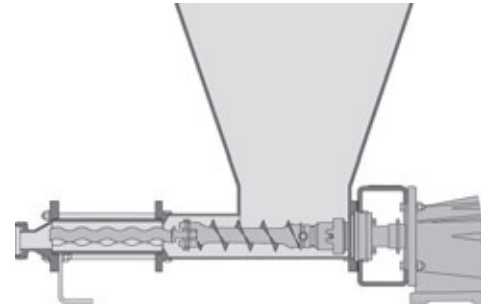

Range MDT _____

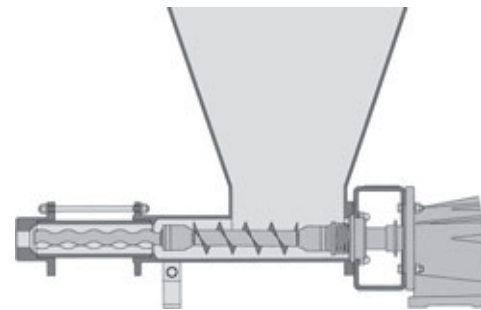

Range MDF _____

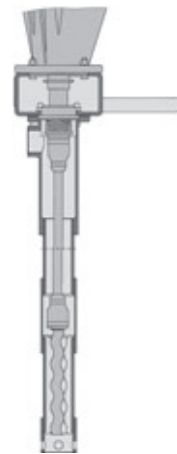

E – Semi-submersible pumps

Semi-submersible pumps are installed vertically. They pump liquids of different viscosities, which may be abrasive or even corrosive. Due to their high efficiencies, a minimal footprint and their maintenance-friendly design, seepex semi-submersible pumps have low life-cycle costs and are a viable alternative to other pump systems.

Features

- Service-friendly with a standard atmospherically cooled drive
 - Customised lengths
 - Various installation configurations are available to suit the most unusual applications
 - Space-saving construction
 - Overcomes NPSHA limitations
- > Conveying capacity: up to 300 m³/h (1300 GPM),
Pressure: up to 12 bar (180 psi)

Range BE

Semi-submersible variant U



Range BE

Semi-submersible variant O

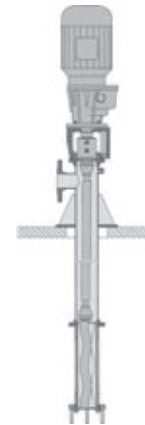

Range BE

Semi-submersible variant K



Range BE

Semi-submersible variant W



W – Wobble pumps

Wobble pumps in block design perform well in almost all industries. They convey liquids of all viscosities, even those with high solids, are very simple to use and particularly efficient.

Features

- Service-friendly and particularly efficient: simple pump structure, rapid replacement of pumping elements
 - Space-saving with a short, compact design, direct flange-mounted drive (block design)
 - Flexible stator, fixed on one end
 - Rotating unit with only one universal joint
- > Conveying capacity: up to 10 m³/h (45 GPM),
Pressure: up to 4 bar (60 psi)

Range BW

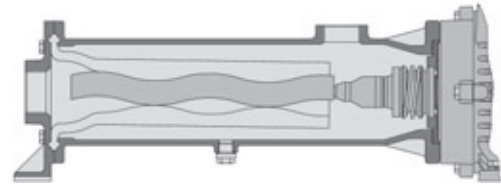

M – Macerators

While the 2 ranges of seepex macerators are primarily used for municipal and industrial wastewater, they are also used for diverse applications in other industries. They chop almost all solid and fibrous components and increase the operating time and service life of the downstream equipment. The degree of maceration can be controlled by varying the flow rate, the drive speed and the shear plate design.

Features

- Longer service life and increase of operational safety of downstream equipment
 - Lower power requirements than other macerating methods due to the unique cutting principle
 - Controlled maceration by using shear plates with holes of different sizes and variable drive speeds
 - Service-friendly with simple replacement of the complete cartridge-style headstock
 - An optional integrated heavy solids separation unit
- > Flow rate: up to 150 m³/h (660 GPM)

Range U

with solids separator

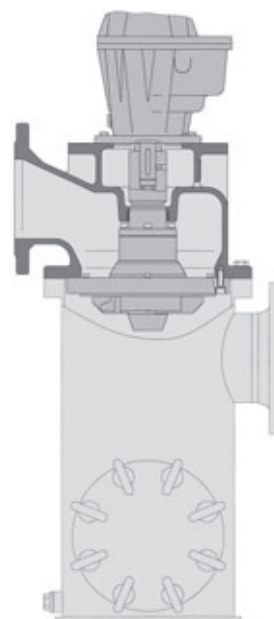

Range I

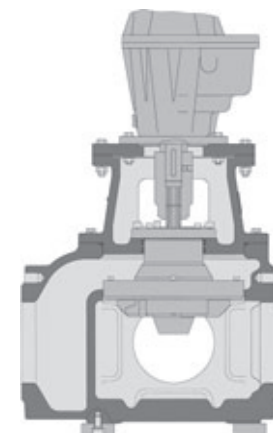

CO – Control systems

We tailor our control systems (CO = Control) to optimise the pump and the process. Standardised modules are available for dosing applications and the pumps protection, e.g. over-pressure or dry-running. In addition, we provide individualised control solutions by consulting with our customers which can include component supply or complete panel design.

Features

- Single source supply of pumps and controls
- Development of customer-specific solutions can be integrated with seepex products
- Simple integration into existing systems
- Standardised modules
- Network-compatible compact controllers
- Competent support including project planning and commissioning
- Optimises pump and process

Switch cupboard



Control module

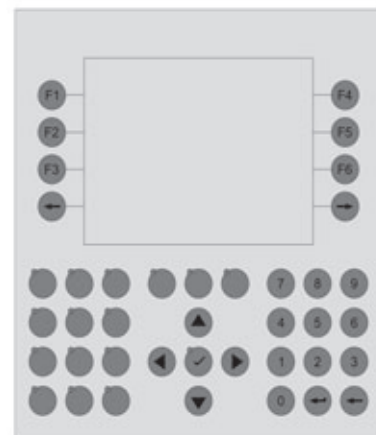

seepex products in particular.

seepex products have been used very successfully and are proven for the most difficult conveying duties. The modular design consisting of 8 product groups and 27 ranges enables

the most economical and technical solution to be selected for each application. It's no surprise that our pumps are indispensable in many industrial areas.

Product groups	>	N	CS	T	D	E	W	M	CO
Environmental Technology									
Domestic waste water treatment		•		•	•	•	•	•	•
Industrial waste water treatment		•		•	•	•	•	•	•
Flocculant metering		•			•	•			•
Sludge dewatering		•		•			•		•
Chemical dosing		•			•	•			•
Flue gas desulfuration		•		•			•		
Oil-water-separation		•			•	•	•		
Utilities/Disposal									
Fresh-water conditioning		•		•	•		•		
Transport of landfill drainage water		•			•	•	•		
Chemical dosing		•			•	•			•
Galvanic									
Chemical dosing		•			•	•			•
Disposal of process waste		•		•	•	•	•	•	
Food/Beverage Industry									
Dairy		•		•		•			
Processed fruit and beverages		•	•	•	•	•	•		
Wine production		•	•	•			•		•
Processed vegetables and meat		•	•	•	•	•	•		
Breweries		•	•	•	•	•	•		•
Pharmaceutical/Cosmetic Industry									
Dryer feeding		•					•		
Metering of additives		•	•	•	•	•			
Filling of endproducts		•	•	•	•	•	•		
Fish Industry									
Fish meal production		•		•			•		
Fish processing		•	•	•	•	•	•	•	
Fish feeding		•		•		•	•	•	
Fish transportation		•		•		•	•	•	
Petrochemical/Oil Production/Offshore									
Bilge-pumping		•				•	•		•
Oil-water-separation		•					•		
Transportation of waste water and excrements		•			•	•	•	•	
Drilling mud treatment		•		•	•	•	•		
Drainage and fire fighting		•		•		•	•		
Production of chemicals		•		•	•	•	•		
Mining									
Auxiliary dewatering stations		•				•	•		
Sump dewatering		•		•		•	•		
Dedusting		•					•		
Flocculant metering		•				•			•
Pressure filter feeding		•					•		•
Back filling and grout		•		•			•		
Paper and Cellulose Industry									
Stock preparation		•		•	•	•	•	•	
Paper/cardboard production		•		•		•	•		
Coating processing		•			•		•		
Adhesive and pigment processing		•			•		•		
Coater feed		•					•		
Metering of chemicals		•			•				•
Waste water treatment		•		•	•	•	•	•	•

Product groups	>	N	CS	T	D	E	W	M	CO
Dyeing Industry									
Metering and filling of colors		•	•	•	•	•			•
Component metering		•	•		•	•			•
Latex foaming		•	•		•	•	•		
Waste water treatment		•		•	•	•	•	•	•
Ships									
Bilgewater handling		•				•	•		
Oil-water separation		•			•	•	•		
Liquid-mud transport		•				•	•		
Waste disposal		•		•		•	•	•	
Textile Industry									
Dye metering		•	•	•	•	•			
Transport of printing ink		•			•	•	•		
Feeding of Latex coaters		•			•	•	•		
Automotive/Equipment									
Dewaxing		•			•	•	•		
Mobile dewatering		•		•	•	•	•		
Transport of sealing compounds and protective coatings		•		•	•	•	•		
Waste oil disposal		•		•	•	•	•		
Paint and enamel processing		•			•	•	•		
Building Industry									
Plaster and gypsum		•		•			•		
Concrete coloring		•			•	•	•		
Tunnel grout		•		•			•		
Waste water/sludge treatment		•			•	•	•	•	•
Dewatering		•				•	•		•
Wood Processing									
Production of partical boards and MDF boards		•			•	•	•		
Lime metering		•			•	•	•		
Metering of additives		•			•	•	•		
Chemical/Biochemical Industry									
Polymer production		•	•	•	•	•	•		
Metering of additives		•	•	•	•	•	•		
Processing of reaction agents		•	•	•	•	•	•		
Dispersion handling		•	•	•	•	•	•		
Sugar Industry									
Processing of sugar cane and beets		•		•		•	•		
Diffusion, saturation, thickening		•		•		•	•		
Crystalization		•		•			•		
Centrate		•		•			•		
Waste water treatment		•		•	•	•	•	•	•
Ceramic Industry									
Handling of suspensions		•		•			•		
Metering of additives		•			•				
Agriculture									
Feeding plants		•		•	•	•	•		•
Liquid manure transportation		•		•		•	•	•	
Bio gas plant		•		•	•	•	•	•	
Irrigation systems		•					•		

The seepex speciality: system solutions.

seepex is not only well known as leader in the manufacture of progressive cavity pumps, but it is increasingly recognised by its customers as expert in the design and supply of customised fluid/product-handling solutions. seepex's highly qualified engineers are outstanding in their professionalism, their knowledge of pumps, their applications and the industry sectors they support. They take pride in their ability to listen, understand customer's problems and create innovative engineering solutions that bring results.

seepex progressive cavity pumps and accessories, include piping, fittings and measuring devices as well as electronic controllers. These are optimized and integrated for each specific application. We consider the complete engineering task, including documentation and project planning.

For example, seepex system solutions include

- Pump systems for specific metering applications including PLC controllers and instrumentation
- Assembly of one or more pumps on special skids with associated pipe work
- Process controllers and control cabinets
- Reception hoppers and handling systems for dewatered sludge
- Pumps with engine drives on portable skids
- Pumps on trolleys

Additionally, we offer a complete Aftersales portfolio which includes installation and commissioning together with a full range of services to support the pump throughout the complete life cycle.

User Advantages

Rotor - Stator-Geometries

seepex 6L - conventional geometry comparison

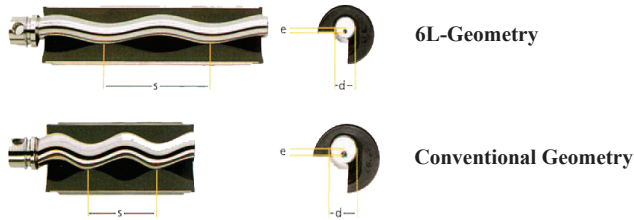

smaller rotor diameter
 + reduced eccentricity
 + increased pitch length
 = 6L-Geometry with 20 % lower sliding velocity

- Improved service life (+35-50%) due to lower sliding velocity and longer sealing line
- Better pressure stability due to wider sealing line
- Reduced thrust loads on universal joints and bearings due to smaller rotor diameter and lower eccentricity
- Thrust loads of the conventional design exceed the thrust loads of the 6L-Geometry by approx. 50 %
- Smooth and almost pulsation-free operation
- The “stretched cavities” have a positive influence on vibrations, turbulences, pulsation and shear rates

seepex Universal Joint Design

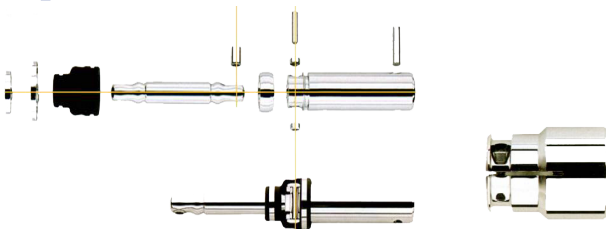

Benefits

- Only 4 hardened and wear resistant universal joint components (1 coupling rod bush, 2 guide bushes, 1 coupling rod pin)
- Positively sealed, gas and liquid tight elastomer universal joint sleeve
- Optional stainless steel universal joint sleeve protector with unconditioned - 10.000 h/24 months guarantee on the protected universal joint
- Simple and cost-effective to maintain
- Streamlined design, thus improved NPSH conditions
- Simple and cost-effective to maintain

seepex has The Optimum Rotor Surface

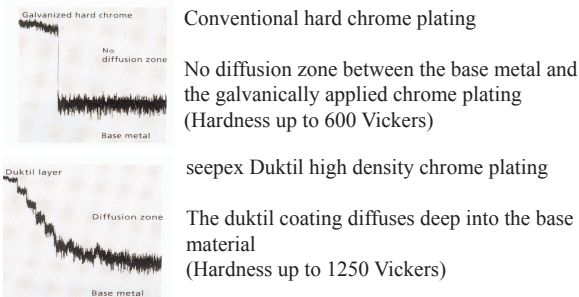

Benefits of the high quality seepex rotor surface

- Reduced starting and operating torque
- Improved efficiencies
- Smoother operations
- Increased service life
- The hardness of the coating is 1250 Vickers versus 180 of the base material
- The adhesion to the base material is excellent with no surface fissures

seepex Molded to size stators

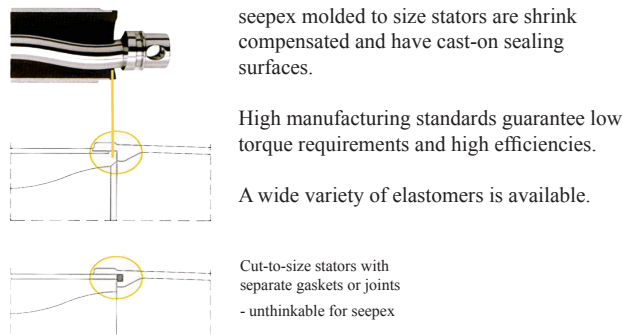

seepex molded to size stators are shrink compensated and have cast-on sealing surfaces.

High manufacturing standards guarantee low torque requirements and high efficiencies.

A wide variety of elastomers is available.

Cut-to-size stators with separate gaskets or joints - unthinkable for seepex

seepex Optional TSE Dry Run Protection

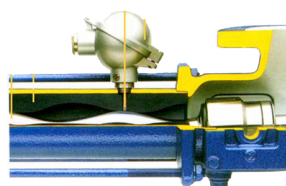

Benefits

- Universal solution for all applications protects pump and stator against damages caused by frictional heat due to lack of liquid pumped
- Highly efficient low cost dry running protection system



TSE controller for panel mounting



Complete IP55 (NEMA 4) pump control panel with incorporated TSE controller

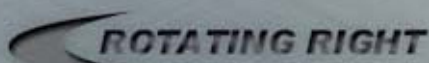

Head Office:
 6120 Davies Road
 Edmonton, AB
 T6E 4M9

Phone: (780) 485-2010 • Toll Free: (866) 707-7867
 Fax: (780) 485-1938
 • Calgary • Drayton Valley • Lethbridge
www.rotatingright.com